

cilindri a cartuccia

cartridge cylinders



- Cilindri a semplice effetto con molla anteriore
Single acting cylinders with front spring
- Non magnetico
Non-magnetic
- Versione con stelo filettato o non filettato
Version with threaded or non-threaded piston rod
- Grande affidabilità e lunga durata
High reliability and long life time



Materiali

Camicia: ottone nichelato

Stelo: INOX

Dadi: acciaio zincato

Guarnizioni: poliuretano

Molla: acciaio

Materials

Barrel: nickel plated brass

Piston-rod: stainless steel

Nuts: zinc coated steel

Sealings: polyurethane

Spring: steel

AVVERTENZE - WARNING

- Evitare carichi radiali sullo stelo
Avoid side loads on the piston rod

- Evitare di caricare lo stelo quando viene richiamato dalla molla
Do not load the piston rod during the spring retraction

Pressione di esercizio <i>Working pressure</i>	2 ... 7 bar 0.2 ... 0.7 MPa
Temperatura di esercizio <i>Temperature range</i>	max +60°C
Alesaggi <i>Bores</i>	6; 10; 16 mm
Corse <i>Strokes</i>	5; 10; 15 mm
Fluido <i>Fluid</i>	Aria filtrata 50µ con o senza lubrificazione <i>50µ filtered, lubricated or non lubricated air</i>

cilindri a cartuccia

cartridge cylinders

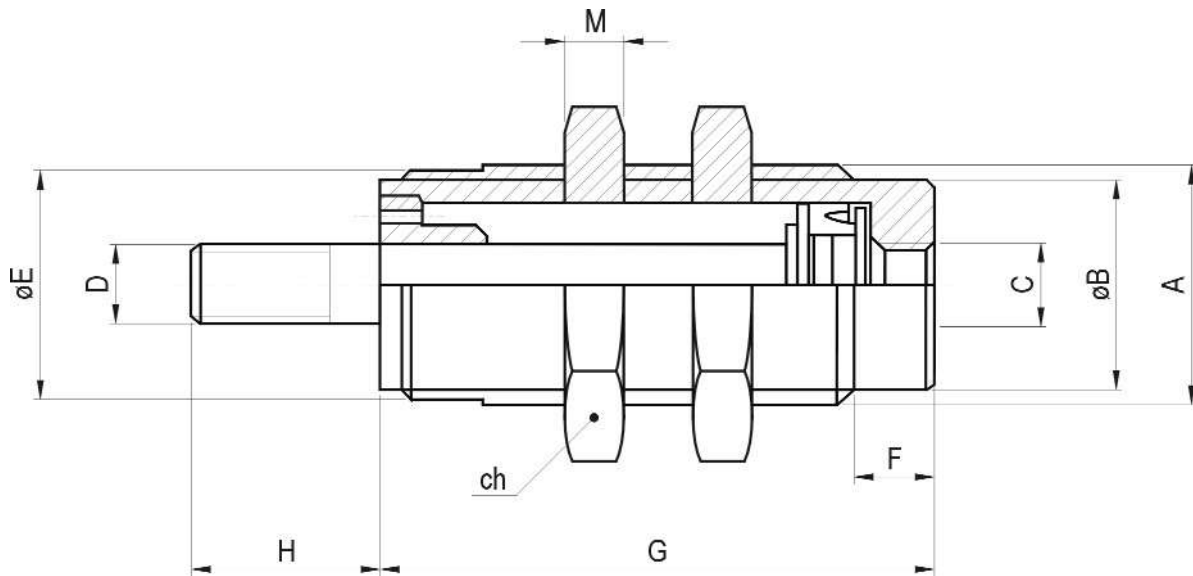

alesaggio bore	A	B	C	D		øE	F	H	M	ch	G		
				con stelo filettato threaded piston rod	con stelo non filettato non-threaded piston rod						corsa cilindro [cyl. stroke]		
6	M10x1	8.5	M5	M3	ø3	9	5	8	3	14	5	10	15
10	M15x1.5	13	M5	M4	ø5	14	5	11.5	4	19	20.5	27	34
16	M22x1.5	19	M5	M5	ø5	20	6	14	5	27	23.5	29.5	36

FORZE a 6 bar - forces at 6 bar

alesaggio bore	forza in spinta press force	forza di ritorno della molla return spring force	
		corsa 0 [stroke 0]	fondo corsa [stroke end]
6	12 N	1.2 N	3.8 N
10	35 N	2.7 N	7.3 N
16	101 N	3.3 N	6.6 N

PESI - weights

alesaggio bore	corsa cilindro [cyl. stroke]		
	5	10	15
6	10 g	13 g	15 g
10	27 g	32 g	36 g
16	71 g	78 g	87 g

CODICI DI ORDINAZIONE - order codes

cilindri con stelo filettato - cylinders with threaded piston rod			
alesaggio bore	corsa - stroke		
	5	10	15
6	20.100.4	20.101.4	20.102.4
10	20.103.4	20.104.4	20.105.4
16	20.106.4	20.107.4	20.108.4

cilindri con stelo non filettato - cylinders with non-threaded piston rod			
alesaggio bore	corsa - stroke		
	5	10	15
6	20.109.4	20.110.4	20.111.4
10	20.112.4	20.113.4	20.114.4
16	20.115.4	20.116.4	20.117.4