

PIEDINO (foot mounting)

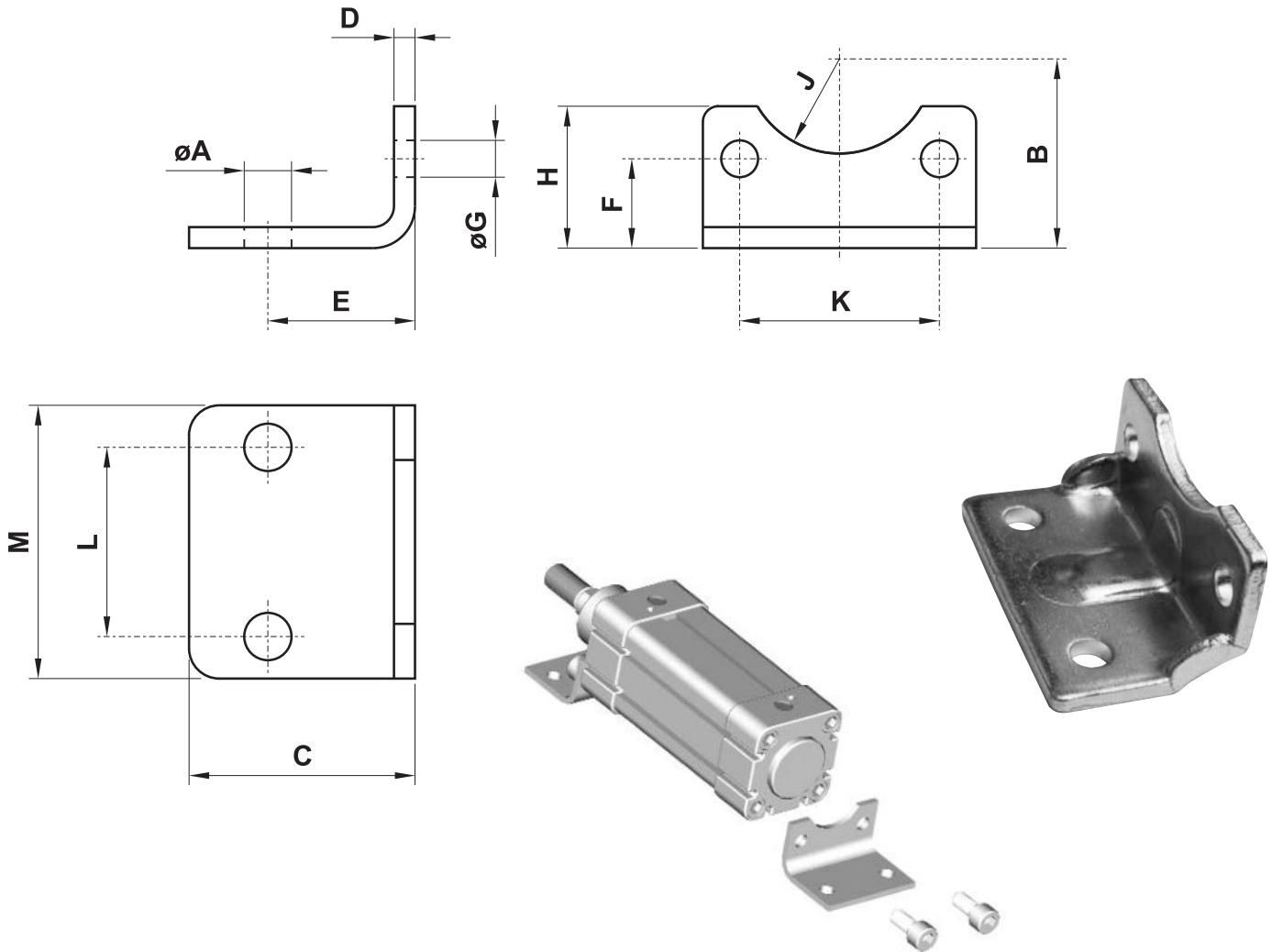

sigla* part number*	per alesaggio for bore	A	B	C	D	E	F	G	H	J	K	L	M
PBIS032	32	7	32	35	4	24	15.75	7	30	15	32.5	32	45
PBIS040	40	9	36	36	4	28	17	7	30	17.5	38	36	52
PBIS050	50	9	45	47	5	32	21.75	9	36	20	46.5	45	65
PBIS063	63	9	50	45	5	32	21.75	9	35	22.5	56.5	50	75
PBIS080	80	12	63	55	6	41	27	11	47	22.5	72	63	95
PBIS100	100	14	71	57	6	41	26.5	11	53	27.5	89	75	115
PBIS125	125	16	90	70	8	45	35	14	70	30	110	90	140
PBIS160	160	18	115	75	9	60	45	18	100	32.5	140	115	180
PBIS200	200	22	135	100	12	70	47.5	18	100	37.5	175	135	220

* La sigla si riferisce a un solo piedino e non alla coppia

* The part number is referred to only one element and not to the couple