

Series MC filter-regulators

Ports G1/4, G3/8 and G1/2
Modular
Metal bowl and bayonet-type mounting



- » Quality of delivered air according to ISO 8573-1:2010, Classes 7.8.4 and 6.8.4
- » Minimal pressure decreases
- » Knob with closure
- » Integral return exhaust (relieving)
- » Available versions: with by-pass valve

Series MC filter regulators are available with ports G1/4, G3/8 and G1/2. They combine the features of the filters and regulators and have smaller overall dimensions than the two separate components.

GENERAL DATA

Construction	compact modular with filtering element in HDPE		
Materials	zama, NBR, technopolymer		
Ports	G1/4	G3/8	G1/2
Condensate capacity	cm ³	28	72
Weight	kg	0,443	0,948
Mounting	vertical in-line or wall-mounting		
Operating temperature	-5°C ÷ 50°C at 10 bar (with the dew point of the fluid lower than 2°C at the min. working temperature)		
Quality of delivered air according to ISO 8573-1:2010	Class 6.8.4 with 5µm filtering element Class 7.8.4 with 25µm filtering element		
Draining of condensate	semi-automatic manual (standard), automatic, with depressurisation, protected depressurisation, without drain with port G1/8		
Finishing	enamelled		
Inlet pressure	with standard drain and protected depressurisation 0.3 ÷ 16 bar with depressurisation 0.3 ÷ 10 bar with automatic drain 1.5 ÷ 12 bar for G3/8 and G1/2		
Outlet pressure	0.5 ÷ 10 bar(standard), 0.5 ÷ 2 bar; 0.5 ÷ 4 bar e 0.5 ÷ 7 bar		
Nominal flow	see FLOW DIAGRAMS on the following pages		
Fluid	compressed air		

CODING EXAMPLE

MC	2	02	-	D	0	0	2	-	4	-	VS
-----------	----------	-----------	----------	----------	----------	----------	----------	----------	----------	----------	-----------

MC	SERIES
2	SIZE: 1 = G1/4 2 = G3/8 - G1/2
02	PORTS: 04 = G1/4 38 = G3/8 02 = G1/2
D	D = FILTER-REGULATOR
0	FILTERING ELEMENT: 0 = 25µm (standard) 1 = 5µm
0	DRAINING OF CONDENSATE (further details in the dedicated section): 0 = manual semiautomatic, self-relieving 1 = manual semiautomatic, non relieving 3 = automatic, self-relieving (only for G3/8 and G1/2) 4 = depressurisation, self-relieving (only G1/4) 5 = depressurisation, protected, self-relieving 8 = no drain, port G1/8, self-relieving
2	PRESSURE GAUGE: ** = without pressure gauge (standard) 1 = with pressure gauge 0-2.5, with working pressure 0.5 ÷ 2 bar 2 = with pressure gauge 0-6, with working pressure 0.5 ÷ 4 bar 3 = with pressure gauge 0-10, with working pressure 0.5 ÷ 7 bar 4 = with pressure gauge 0-12, with working pressure 0.5 ÷ 10 bar
4	WORKING PRESSURE = 0.5 ÷ 10 2 = 0.5 ÷ 2 (only G1/4) 4 = 0.5 ÷ 4 7 = 0.5 ÷ 7 (only G1/4)
VS	REGULATION TYPE: = without by-pass valve (standard) VS = with by-pass valve (only G1/4)
** the pressure gauges are supplied disassembly for size 1 pressure gauge mod. M043-P. for size 2 pressure gauge mod. M053-P.	

SERIES MC FILTER-REGULATORS

Filter-regulators Series MC

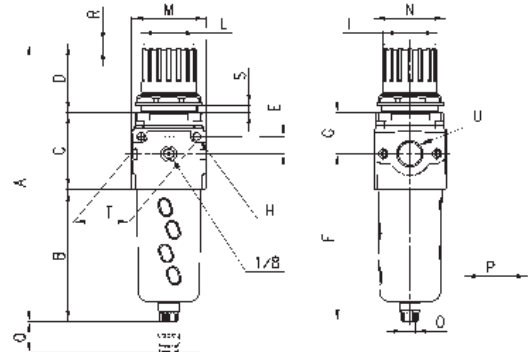

DIMENSIONS																			
Mod.	A	B	C	D	E	F	G	H	I	L	M	N	O	P	Q	R	S	T	U
MC104-D00	190,5	102	52	38	11	126,5	27,5	4,5	28	M30x1,5	45	45	G1/8	37	58	3	0 ÷ 6	35	G1/4
MC238-D00	256,5	133	64	59	14	162	35	5,5	45	M47x1,5	62	59	G1/8	53	72	3,5	0 ÷ 9	46	G3/8
MC202-D00	256,5	133	64	59	14	162	35	5,5	45	M47x1,5	62	59	G1/8	53	72	3,5	0 ÷ 9	46	G1/2

FLOW DIAGRAMS

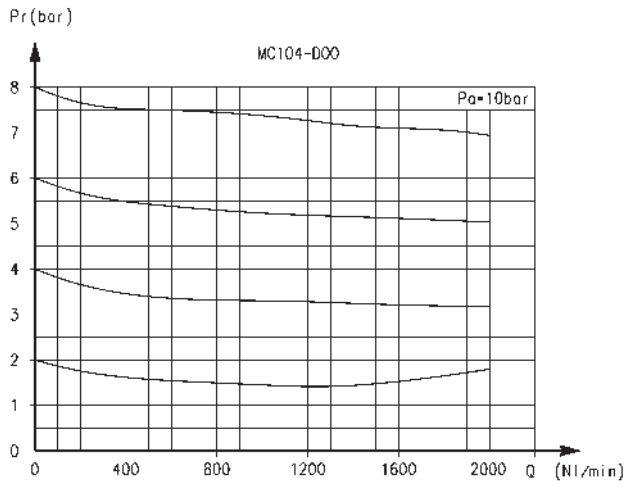

Pa = Inlet pressure (bar)
Pr = Regulated pressure (bar)
Q = Flow (NL/min)

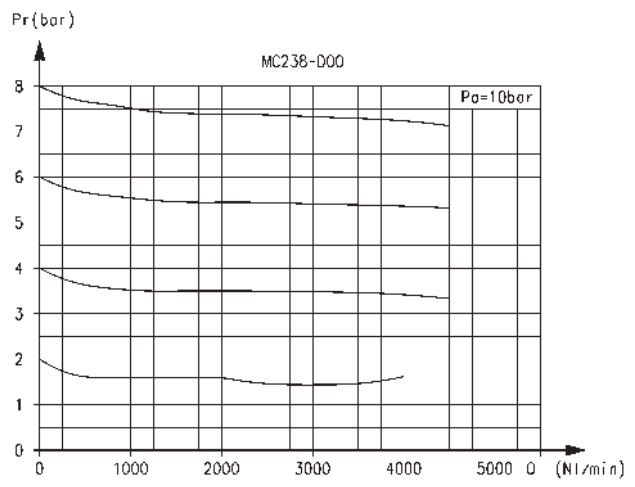

Pa = Inlet pressure (bar)
Pr = Regulated pressure (bar)
Q = Flow (NL/min)

SERIES MC FILTER-REGULATORS

FLOW DIAGRAM AND PNEUMATIC SYMBOLS

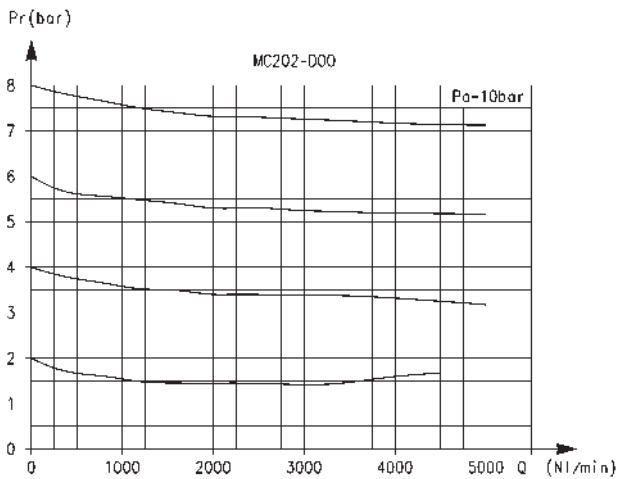

Pa = Inlet pressure (bar)
Pr = Regulated pressure (bar)
Q = Flow (bar)

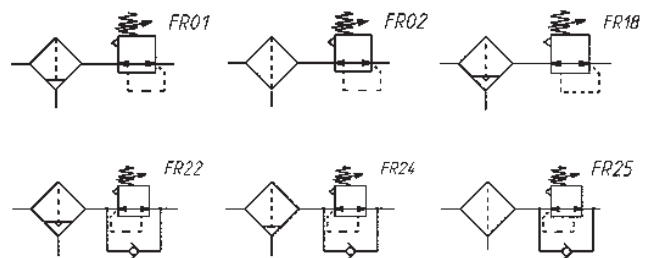

- FR01 = filter-reg. with relieving and manual/semiautomatic drain
- FR02 = filter-reg. with relieving and direct exhaust
- FR18 = filter-reg. with relieving and automatic drain
- FR22 = filter-reg. relieving, with pressure gauge, automatic-depressurisation drain and by-pass valve
- FR24 = filter-reg. with relieving and manual/semiautomatic drain and by-pass valve
- FR25 = filter-reg. with relieving, direct exhaust and by-pass valve