

fissaggi per cilindri tondi

fixing elements for round cylinders

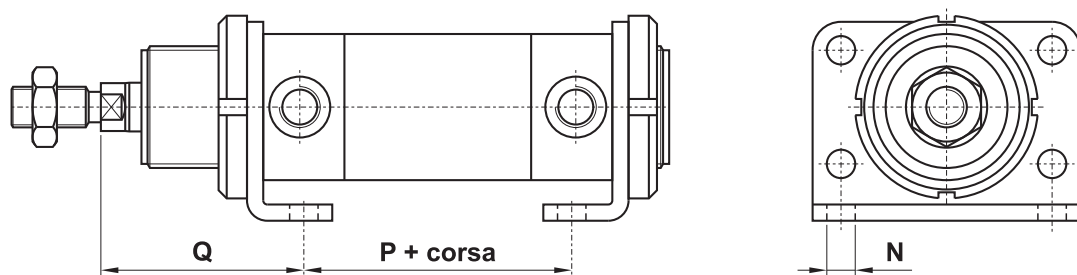

PIEDINO

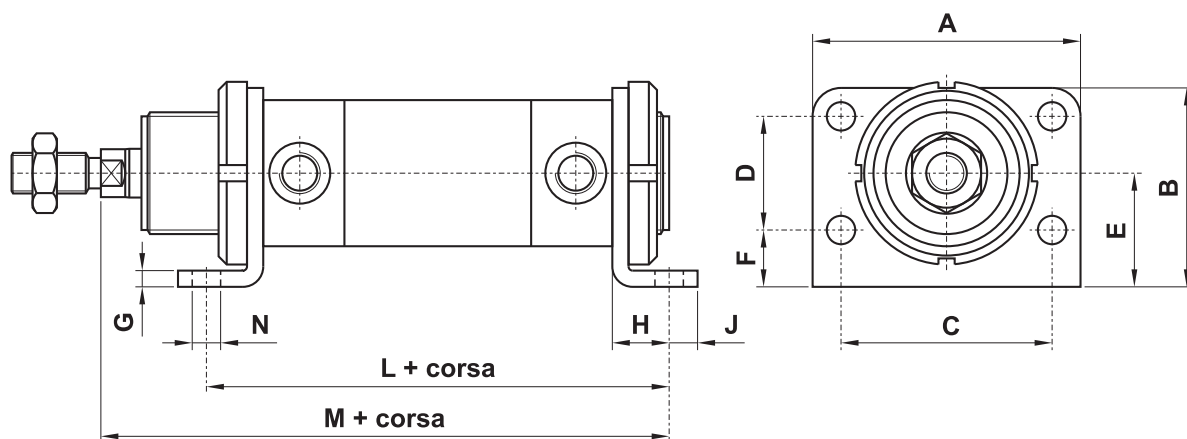

sigla* part number*	per alesaggio for bore	A	B	C	D	E	F	G	H	J	L	M	N	P	Q
FPT032	32	66	49	52	28	28	14	4	14	7	124	148	ø7	76	48
FPT040	40	80	58	60	30	33	18	5	20	10	153	178	ø9	83	60
FPT050	50	90	70	70	40	40	20	6	20	10	160	190	ø9	92	64

* La sigla si riferisce a un solo piedino e non alla coppia

* The part number is referred to only one element and not to the couple